

Revision History

Rev	Description	Date	Approved
A	Initial Release	07/01/24	JB

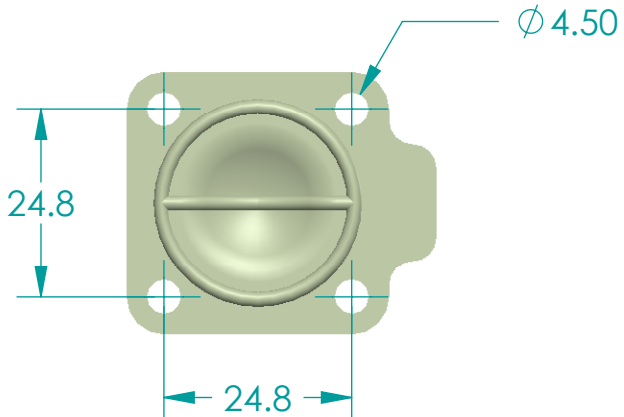
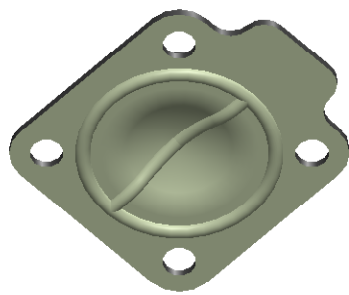
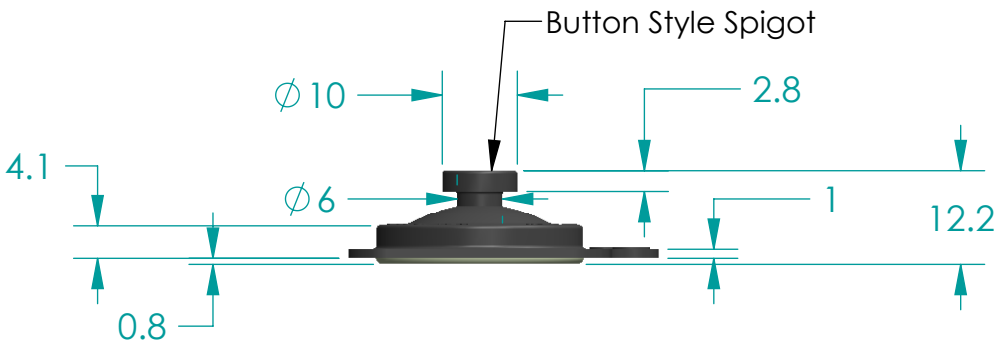
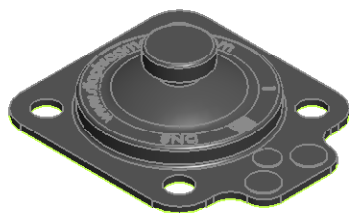
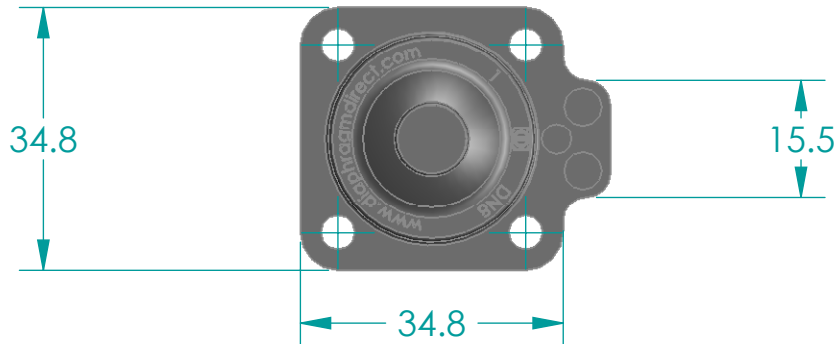

Replacement Diaphragm for:-
OEM PART = 677674 or 679540
USED ON DN8 Diaphragm Valve

	Name	Date	
Drawn	M.Mc Keon	15/06/24	
Checked			TITLE DD03-TTFML
Material - EPDM-BACKING TFM - DIAPHRAGM			
Complies with CFR 177.2600 and Conforms to USP Class VI Biological Reactivity Tests Section #87 and #88			Size A FOOT PRINT DIMENSIONS
File Name:			Rev A
SCALE: 1:1			Sheet 1 of 1

Disclaimer - Diaphragm Direct® does not manufacture, represent, nor sell OEM valves or diaphragms manufactured by any other company. Diaphragm Direct® brand diaphragms are not sponsored by any other manufacturers. Any name, model, part number, brand, image, material or referral is for descriptive purposes only. Diaphragm Direct® brand replacement diaphragms are guaranteed to fit OEM equipment and meet or exceed OEM specifications. Diaphragm Direct® brand replacement diaphragms are covered by the standard Diaphragm Direct® limited product warranty.